

## **ПІДТВЕРДЖУВАЛЬНЕ ПОВІДОМЛЕННЯ**

Державне підприємство  
«Український науково-дослідний і навчальний центр  
проблем стандартизації, сертифікації та якості»  
(ДП «УкрНДНЦ»)

Наказ від 25.12.2015 № 207 (у редакції наказу від 20.05.2016 № 137)

**EN 1708-1:2010**

**Welding — Basic welded joint details in steel — Part 1: Pressurized components**

прийнято як національний стандарт  
методом «підтвердження» за позначенням

**ДСТУ EN 1708-1:2015**  
**(EN 1708-1:2010, IDT)**

**Зварювання. Зварні з'єднання сталевих елементів Частина 1.**  
**Зварні з'єднання конструкційних елементів, що працюють під тиском**

З наданням чинності від 2016–01–01

English Version

## Welding - Basic welded joint details in steel - Part 1: Pressurized components

Soudage - Descriptif de base des assemblages soudés en acier - Partie 1: Composants soumis à la pression

Schweißen - Verbindungselemente beim Schweißen von Stahl - Teil 1: Druckbeanspruchte Bauteile

This European Standard was approved by CEN on 28 November 2009.

CEN members are bound to comply with the CEN/CENELEC Internal Regulations which stipulate the conditions for giving this European Standard the status of a national standard without any alteration. Up-to-date lists and bibliographical references concerning such national standards may be obtained on application to the CEN Management Centre or to any CEN member.

This European Standard exists in three official versions (English, French, German). A version in any other language made by translation under the responsibility of a CEN member into its own language and notified to the CEN Management Centre has the same status as the official versions.

CEN members are the national standards bodies of Austria, Belgium, Bulgaria, Croatia, Cyprus, Czech Republic, Denmark, Estonia, Finland, France, Germany, Greece, Hungary, Iceland, Ireland, Italy, Latvia, Lithuania, Luxembourg, Malta, Netherlands, Norway, Poland, Portugal, Romania, Slovakia, Slovenia, Spain, Sweden, Switzerland and United Kingdom.

**Management Centre: Avenue Marnix 17, B-1000 Brussels**

## Contents

Page

Foreword.....	3
1 Scope .....	4
2 Normative references .....	4
3 Requirements .....	4
3.1 Selection of detail .....	4
3.2 Joint preparation (geometry and size).....	5
3.2.1 General.....	5
3.2.2 Joint preparation geometry .....	5
3.2.3 Weld sizes.....	5
3.3 Presentation .....	5
3.4 Removal of internal sharp edges in branch bores .....	5
3.5 Preparation of holes in shell for set-through branches.....	6
3.6 Welds for smooth transition .....	6
3.7 Oblique and tangential branches .....	6

## Tables

Table 1 — Butt joints of different thickness .....	7
Table 2 — Branches without compensation rings .....	11
Table 3 — Branches with compensation rings.....	23
Table 4 — Sockets and couplings.....	25
Table 5 — Flanges .....	27
Table 6 — Jacketed vessels .....	31
Table 7 — Tube to tube plate connection.....	42
Table 8 — Flate end or tube plate to shell connections .....	46
Table 9 — Internal diaphragms and separators .....	53
Table 10 — Supports and non-pressure parts.....	54
Table 11 — Special shell to head end connections .....	61
Table 12 — Weld ring seal .....	62
Table 13 — Pipe details .....	64
Table 14 — Block flanges .....	70

## Foreword

This document (EN 1708-1:2010) has been prepared by Technical Committee CEN/TC 121 "Welding", the secretariat of which is held by DIN.

This European Standard shall be given the status of a national standard, either by publication of an identical text or by endorsement, at the latest by July 2010, and conflicting national standards shall be withdrawn at the latest by July 2010.

Attention is drawn to the possibility that some of the elements of this document may be the subject of patent rights. CEN [and/or CENELEC] shall not be held responsible for identifying any or all such patent rights.

This document supersedes EN 1708-1:1999.

EN 1708, *Welding — Basic weld joint details in steel*, consists of the following parts:

- *Part 1: Pressurized components*
- *Part 2: Non internal pressurized components*

According to the CEN/CENELEC Internal Regulations, the national standards organizations of the following countries are bound to implement this European Standard: Austria, Belgium, Bulgaria, Croatia, Cyprus, Czech Republic, Denmark, Estonia, Finland, France, Germany, Greece, Hungary, Iceland, Ireland, Italy, Latvia, Lithuania, Luxembourg, Malta, Netherlands, Norway, Poland, Portugal, Romania, Slovakia, Slovenia, Spain, Sweden, Switzerland and the United Kingdom.



## 1 Scope

The purpose of this European Standard is to exemplify commonly accepted welded connections in pressure systems. It does not promote the standardization of connections that may be regarded as mandatory or restrict development in any way. Stress analysis rules should be considered if necessary.

This standard contains examples of connections welded by:

- Manual metal-arc welding with covered electrode (111);
- Submerged arc welding (12);
- Gas shielded metal arc welding (13);
- Tungsten inert gas arc welding; TIG-welding (14);
- Plasma arc welding (15)

processes (process numbers according to EN ISO 4063) in steel pressure systems. Other processes by agreement.

This standard covers welded joint details in steel, but can be applied to other metallic materials. In such cases the shape and dimensions of the weld should be checked.

The estimation of the suitability of welded connections for special service conditions, for example corrosion and fatigue are not specially considered.

## 2 Normative references

The following referenced documents are indispensable for the application of this document. For dated references, only the edition cited applies. For undated references, the latest edition of the referenced document (including any amendments) applies.

EN ISO 4063, *Welding and allied processes — Nomenclature of processes and reference numbers (ISO 4063:2009)*

EN ISO 5817, *Welding — Fusion-welded joints in steel, nickel, titanium and their alloys (beam welding excluded) — Quality levels for imperfections (ISO 5817:2003, corrected version:2005, including Technical Corrigendum 1:2006)*

EN ISO 9692-1:2003, *Welding and allied processes — Recommendations for joint preparation — Part 1: Manual metal-arc welding, gas-shielded metal-arc welding, gas welding, TIG welding and beam welding of steels (ISO 9692-1:2003)*

EN ISO 9692-2:1998, *Welding and allied processes — Joint preparation — Part 2: Submerged arc welding of steels (ISO 9692-2:1998)*

## 3 Requirements

### 3.1 Selection of detail

Connections are not considered to be equally suitable for all service conditions, nor is the order in which they are shown indicative of their relative characteristics. In selecting the appropriate detail to use from the several

alternatives shown for each type of connection, consideration shall be given to existing fabrication and service conditions that pertain.

## 3.2 Joint preparation (geometry and size)

### 3.2.1 General

The limitations quoted in weld profiles and sizes are based on commonly accepted practice, but they may be subjected to modifications if required by special welding techniques or design conditions, which should be included in the design documents and in the welding procedure specifications (WPS).

### 3.2.2 Joint preparation geometry

Examples of recommended joint preparation geometry (e.g. bevel angles, root radius, presence of backing strips, root faces) are referred to EN ISO 9692-1 when applicable and to EN ISO 9692-2 relative to submerged arc welding process. Missing dimensions of preparations are in accordance with EN ISO 9692-1.

In case where full penetration butt joints are indicated, it is intended that they shall be back chipped or gouged and back welded, or alternatively that the welding procedure shall be such as to ensure sound, effective root penetration.

For relevant difference of thickness (generally a difference of about 3 mm (see Table 1, no. 1.1.1 to 1.1.6) could be considered relevant; in any case the thickness of material shall be taken into account, as well as the shape of the joint) of parts to be butt welded, the thickest element shall be shaped with a slope of 1:5 up to 1:2. Smoother transition of wall thickness is applicable in severe service conditions.

### 3.2.3 Weld sizes

The thickness of welds (in particular of fillet welds), which are not determined by their profile, are based on the assumption that the connection need not be stronger than the connected parts.

## 3.3 Presentation

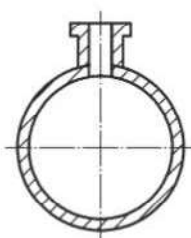

Figure 1 — Transversal section

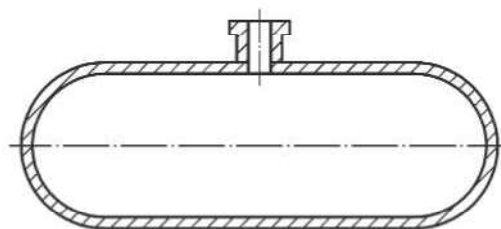

Figure 2 — Longitudinal section

The drawings of the nozzle and branch connections (see Tables 2 and 3) show a transversal section of the connection (see Figure 1) and a longitudinal section of the connection (see Figure 2).

## 3.4 Removal of internal sharp edges in branch bores

It will be noted that the internal edges on the bores of branches are shown partially radiused (for example see Table 2, no. 2.1.6) because a stress concentration occurs at this point. The rounding of the edges is recommended when the branch connection is subjected to severe service conditions like fatigue, creep and stress corrosion.

### 3.5 Preparation of holes in shell for set-through branches

In case of set-in and set-through branches (according to Table 2, no. 2.2 and no. 2.3) holes in the shell may be cut and profiled in two ways as follows:

- The depth of the grooves  $h_1$  and  $h_2$  may be constant around the hole as shown in Figure 3.

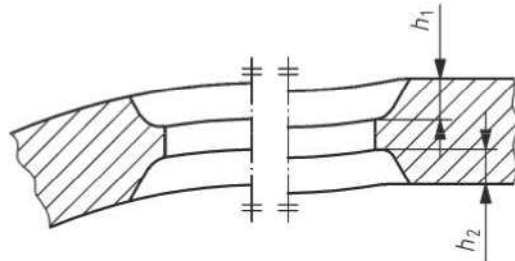

**Key**  
 $h_1, h_2$  depth of the grooves

**Figure 3 — Preparation of holes in the shell**

- The roots of the joint preparations may be in one plane, as for example when they are machine drilled, in which case the depths of the grooves will vary around the hole as shown in Figure 4.

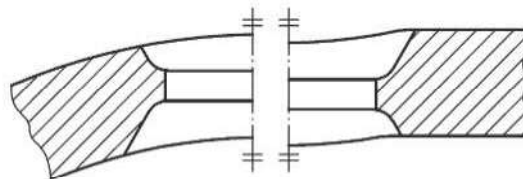

**Figure 4 — Preparation of holes in the shell**

### 3.6 Welds for smooth transition

In some cases it is convenient to foresee a fillet weld providing smooth geometric transition from the surface of one welded part to the surface of the other one, e.g. from branch to shell. Its purpose is to soften the notch effect in the branch-shell edge and therefore the throat thickness is not presented on the figure concerned.

### 3.7 Oblique and tangential branches

The welded connections are contained in Tables 1 to 13. Regarding branches, the oblique and tangential ones are not specially considered as their preparation is similar to that reported on Tables 2 and 3 for radial branches. Only some significant cases are therefore considered (see Table 2, no. 2.2).

**NOTE 1** The welds are only blackened in the following tables when the figures do not give information about the dimension of the values for the preparation.

**NOTE 2** It is not intended that the values of the dimension given in the tables should be measured precisely but rather the general philosophy should be applied.

Table 1 — Butt joints of different thickness





no.	Figure	Application/ condition	Note	Reference to EN ISO 9692-1:2003 and EN ISO 9692- 2:1998
<b>1.1 Butt joints in plates of different thickness</b>				
1.1.1		$\alpha \leq 30^\circ$ $t_1 < t_2$	In case of severe service conditions, the design shall be in accordance with Figures 1.1.2 and 1.1.3. $e \leq 0,1 t_1$ max. 2 mm (for one side welding)	1.5 and 2.3
1.1.2		$\alpha \leq 30^\circ$ $t_1 < t_2$		1.5, 2.3 and 2.5.2
1.1.3		$\alpha \leq 30^\circ$ $t_1 < t_2$	for ultrasonic test $h > 3 t_1$ , but min. 20 mm for radiographic test $h \geq t_1$	1.5, 2.3 and 2.5.2
1.1.4		$\alpha \leq 30^\circ$	see 1.1.1	2.5.1

Table 1 (continued)

no.	Figure	Application/ condition	Note	Reference to EN ISO 9692-1:2003 and EN ISO 9692- 2:1998
1.1.5		$\alpha \leq 30^\circ$		2.5.1
1.1.6		$\alpha \leq 30^\circ$	for ultrasonic test $h > 3 t_1$ , but min. 20 mm for radiographic test $h \geq t_1$	2.5.1

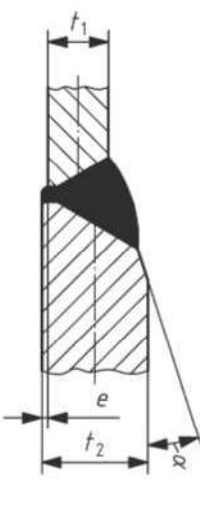
Table 1 (continued)

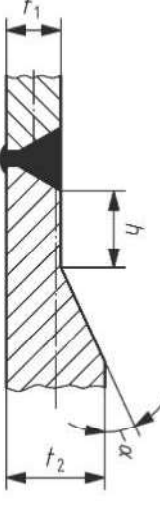
no.	Figure	Application/ condition	Note	Reference to EN ISO 9692-1:2003 and EN ISO 9692- 2:1998
1.1.7		longitudinal weld: $h_1 \leq 0,15 t_1$ ; maximum 3 mm $h_2 \leq 0,3 t_1$ ; maximum 6 mm $t_2 - t_1 \leq 0,3 t_1$ ; maximum 6 mm  circumferential weld: $h_1 \leq 0,2 t_1$ ; maximum 5 mm $h_2 \leq 0,4 t_1$ ; maximum 10 mm $t_2 - t_1 \leq 0,4 t_1$ ; maximum 10 mm		

Table 1 (continued)

no.	Figure	Application/ condition	Note	Reference to EN ISO 9692-1:2003 and EN ISO 9692- 2:1998
1.1.8			Fully penetrated or sealing run	

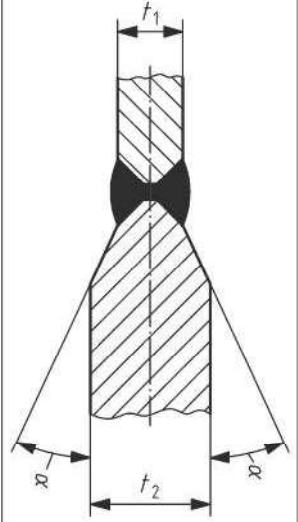
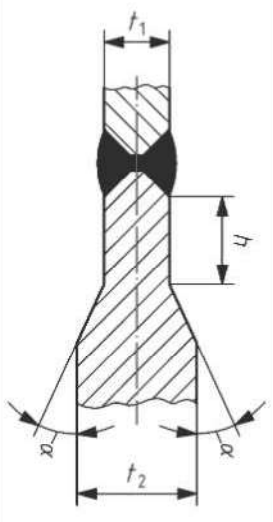
Table 2 — Branches without compensation rings

no.	Figure	Application/ condition	Note	Reference to EN ISO 9692-1:2003 and EN ISO 9692- 2:1998
These connections include the provision of compensation by thickening of the branch and/or shell.				
<b>2.1 Set-on branches</b> (for special branch connections see 13.2)				
If the shell is stressed in direction of the thickness, it should be examined for laminations before setting on the branch.				
2.1.1		$t_1 < 0,5 t_2$ $45^\circ \leq \alpha \leq 60^\circ$		1.9.1 or 1.11 one side welding
2.1.2		$45^\circ \leq \alpha_1 \leq 60^\circ$ $30^\circ \leq \alpha_2 \leq 45^\circ$	These details are recommended only where the bore of the branch is readily accessible for welding. The joint should be back-gouged from the side most accessible and suitable for this purpose generally from the outside.	2.9.1, 2.9.2 or 2.11

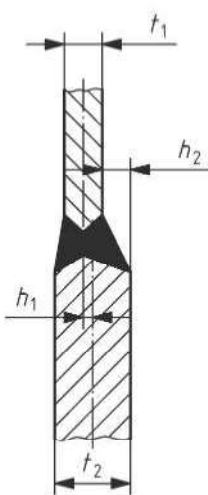

Table 2 (continued)

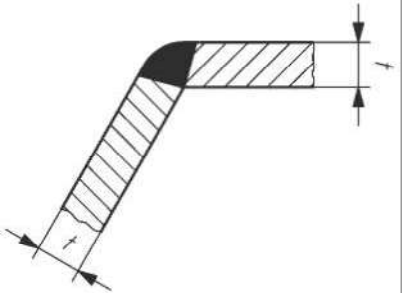
no.	Figure	Application/ condition	Note	Reference to EN ISO 9692-1:2003 and EN ISO 9692- 2:1998
2.1.3		$\alpha_1 = 30^\circ$ $\alpha_2 = 45^\circ$	See 2.1.2	
2.1.4		no gap $c \geq 1,5 \text{ mm}$ $r \geq 5 \text{ mm}$ $\alpha = 30^\circ$	<ul style="list-style-type: none"> <li>— Joints generally used for small branch to shell diameter ratios.</li> <li>— Diameter <math>d</math> to be bored out after welding to remove the weld root, in order to ensure sound weld.</li> </ul>	1.9.1 or 1.11 one side welding

Table 2 (continued)

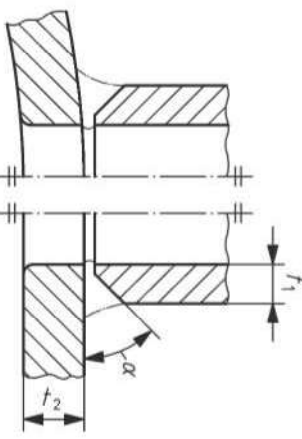
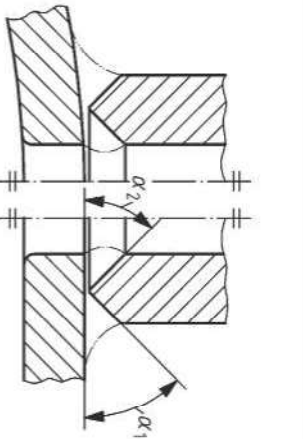
no.	Figure	Application/ condition	Note	Reference to EN ISO 9692-1:2003 and EN ISO 9692- 2:1998
2.1.5		<p>10 mm ≤ l ≤ 15 mm h ≥ 3 mm 30° ≤ α ≤ 45°</p>	<p>Joints generally used for small branch to shell diameter ratios.</p>	<p>1.11 one side welding</p>
2.1.6		<p>For branches up to approximately 100 mm bore. 1 mm ≤ b ≤ 3 mm h ≤ 5 mm c = 1 mm r = 7 mm α<sub>1</sub> ≤ 45° α<sub>2</sub> ≤ 45°</p>	<p>Generally used for the attachment of branches to thick-walled shells.</p>	

Table 2 (continued)

no.	Figure	Application/ condition	Note	Reference to EN ISO 9692-1:2003 and EN ISO 9692- 2:1998
2.1.7		$h \leq 3 \text{ mm}$	The sizes of the fillet welds should be based on the loads transmitted, paying due attention to other fabrication and service requirements.	
2.1.8		$r = 3 \text{ mm}$ $E = 6 \text{ mm}$ $F = 1,5 \text{ mm}$ $\alpha = 30^\circ$ 1 = Profile to meet design requirements	For tubes or nozzles up to approximately 100 mm bore and 6 mm wall thickness $t$ .	
2.1.9		$A = 5 \text{ mm}$ $B = 5 \text{ mm}$ $C = 5 \text{ mm}$ $E = t$ $F = 1,5 \text{ mm}$ $G = 0,5 \text{ mm}$ $\alpha = 30^\circ$ 1 = Profile to meet design requirements	For tubes or nozzles up to and including 150 mm bore and wall thickness $t$ over 6 mm and up to and including 13 mm.	

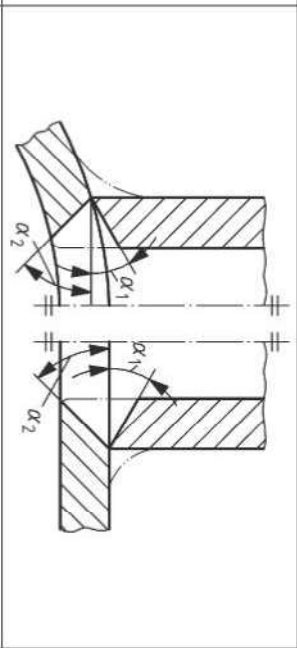
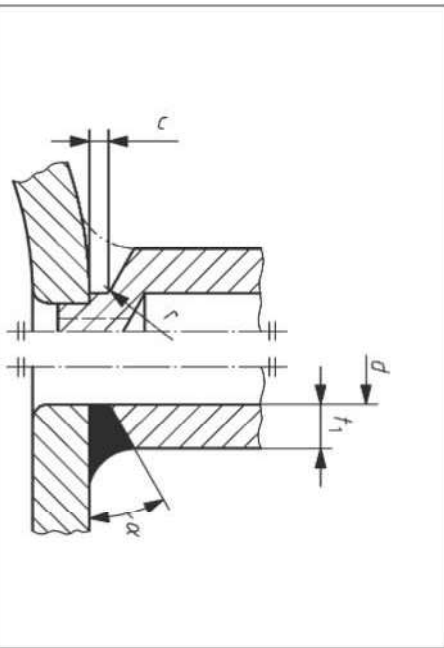
Table 2 (continued)

no.	Figure	Application/ condition	Note	Reference to EN ISO 9692-1:2003 and EN ISO 9692- 2:1998
2.1.10	 <p style="text-align: center;">Dimensions in millimetres</p>	<p>A = 30 mm                      B = 1,5 mm                      H ≥ 3 mm                      M ≥ 10 mm                      N = 5 mm                      W ≥ 2 mm                      r = 6 mm                      α = 30°</p> <p>1 = Fin material                      2 = Weld access hole                      (filled after welding                      tube to header)</p>	<p>Tube panel connections only                      applicable to tubes up to                      100 mm bore and 6 mm wall                      thickness <i>t</i>.</p>	
2.1.11		<p>F = 2 mm                      G = 1,5/2,0 mm                      T = 16 mm max.                      45° ≤ α ≤ 60°</p>	<p>For all tube and nozzle sizes.</p>	

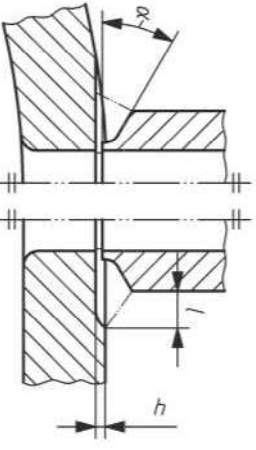
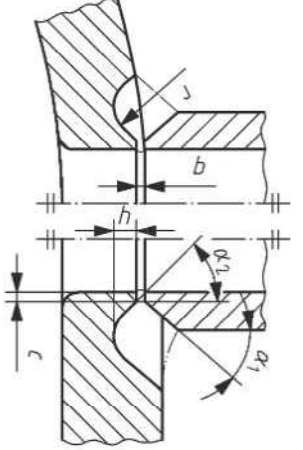
Table 2 (continued)

no.	Figure	Application/ condition	Note	Reference to EN ISO 9692-1:2003 and EN ISO 9692- 2:1998
2.2 Set-in branches (for special branch connection see 13.2)				
As a general recommendation all set-in branches should be welded on the inside of the shell as shown e.g. in Figures 2.2.1 and 2.2.2 if they are accessible for the purpose, otherwise preference should be given to set-on branch connections as shown e.g. in Figure 2.1.1.				
2.2.1		$a = 0,5 t_1$ $h = t_1$ $r \geq 8 \text{ mm}$ $b \leq 1 \text{ mm}$ $10^\circ \leq \alpha \leq 20^\circ$	For partial penetration welded connection.  Generally used when $t_1$ is less than $t_2/2$ . For smaller diameter branches attention is drawn to the details shown in Table 3 which may provide a preferable solution.	1.11 and 3.1.1
2.2.2		$3 \text{ mm} \leq a = 0,5 t_1$ $a_1 < 0,7 t_1$ $b \leq 1 \text{ mm}$	For partial penetration welded connection.  Limited application: — Internal diameter of shell $\leq 200 \text{ mm}$ ; — wall thickness of branch $t_1 \leq 5 \text{ mm}$ .	3.1.1 and 3.1.2

Table 2 (continued)

no.	Figure	Application/ condition	Note	Reference to EN ISO 9692-1:2003 and EN ISO 9692- 2:1998
2.2.3		<p><math>a \geq 5 \text{ mm}</math>  <math>a_1 \leq 0,7 t_1</math>  <math>b \leq 1 \text{ mm}</math>  <math>10^\circ \leq \alpha \leq 20^\circ</math>  <math>r \geq 8 \text{ mm}</math></p>	<p>For partial penetration welded connection.</p>	<p>3.1.2 and 1.11</p>
2.2.4		<p><math>3 \text{ mm} \leq a = 0,5 t_1</math>  <math>a_1 \leq 0,7 t_1</math>  <math>b \leq 1 \text{ mm}</math></p>	<p>For full penetration welded connection.</p>	<p>3.1.2 and 1.11</p>

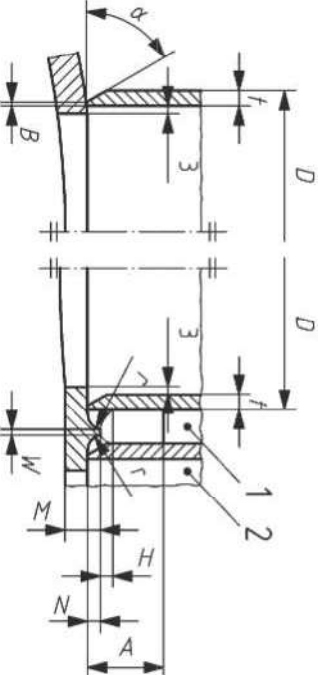
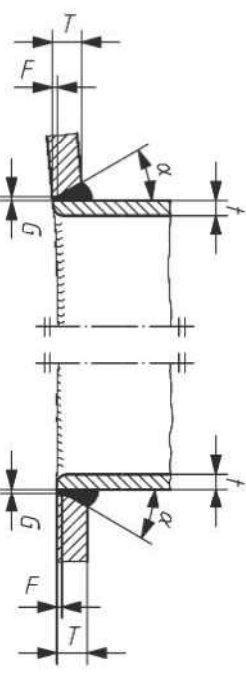
Table 2 (continued)

no.	Figure	Application/ condition	Note	Reference to EN ISO 9692-1:2003 and EN ISO 9692- 2:1998
2.2.5		$h_1 = 0,6 t_1$ $h_2 = t_1$ $b \leq 1 \text{ mm}$ $r \geq 8 \text{ mm}$	For partial penetration welded connection.	2.11
2.2.6		$t_1 \geq 3 \text{ mm}$ $t_2 \leq 3 t_1$ $40^\circ \leq \alpha \leq 60^\circ$	For full penetration welded connection. For joints which are accessible from one side only.	1.9.1 and 1.11
2.2.7		$t_2 \leq 3 t_1$ $30^\circ \leq \alpha \leq 45^\circ$ $2 \text{ mm} \leq b \leq 3 \text{ mm}$ $2 \text{ mm} \leq c \leq 4 \text{ mm}$	For full penetration welded connection.	2.9.1, 2.9.2 and 2.11

Table 2 (continued)

no.	Figure	Application/ condition	Note	Reference to EN ISO 9692-1:2003 and EN ISO 9692- 2:1998
2.2.8		$45^\circ \leq \alpha \leq 60^\circ$ $2 \text{ mm} \leq b \leq 3 \text{ mm}$ $2 \text{ mm} \leq c \leq 4 \text{ mm}$	For full penetration welded connection.	



Table 2 (continued)

no.	Figure	Application/ condition	Note	Reference to EN ISO 9692-1:2003 and EN ISO 9692- 2:1998
2.2.9		$45^\circ \leq \alpha \leq 50^\circ$	To be welded from both sides.	
2.2.10		$3 \text{ mm} \leq a \leq 0,5 t_1$ $45^\circ \leq \alpha \leq 60^\circ$ $2 \text{ mm} \leq b \leq 4 \text{ mm}$		

Table 2 (continued)

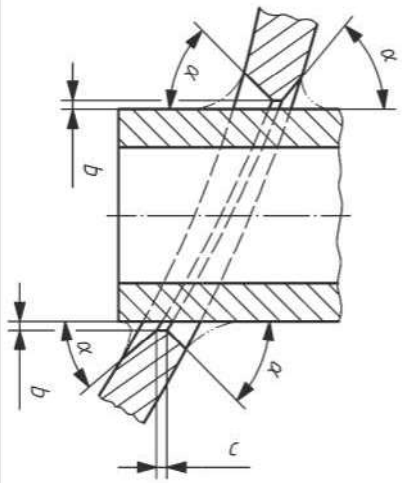
no.	Figure	Application/ condition	Note	Reference to EN ISO 9692-1:2003 and EN ISO 9692- 2:1998
<b>2.3 Set-through branch</b>				
2.3.1		$a = 0,5 t_1$ $b \leq 1 \text{ mm}$	Generally used when $t_1$ is less than $t_2/2$ .	4.1
2.3.2		$h = 0,6 t_1$ $m \geq t_1$	For partial penetration welded connection.	2.11

Table 2 (continued)

no.	Figure	Application/ condition	Note	Reference to EN ISO 9692-1:2003 and EN ISO 9692- 2:1998
2.3.3		$m \geq t_1$	For full penetration welded connection.	2.9.1 and 2.11
<b>2.4 Extruded branch connections (for special branch connections see 13.2)</b>				
2.4.1		$m \geq t_1$ 1 conventional butt joint	Conventional butt joint will be used to weld the branch connection to the shell, and may not necessarily have the form shown. Example of application: Surface coating, e.g. internal rubber lining.	1.5
<b>2.5 Butt welded branches</b>				
2.5.1		1 conventional butt joint		2.5.1, 2.5.2

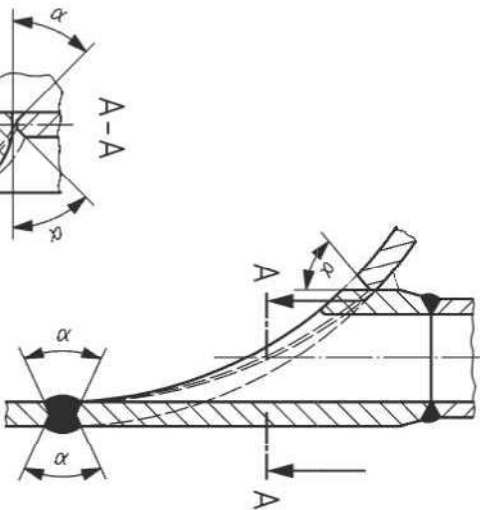
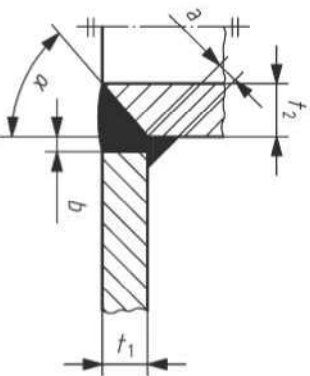
Table 3 — Branches with compensation rings

no.	Figure	Application/ condition	Note	Reference to EN ISO 9692-1:2003 and EN ISO 9692- 2:1998
<p>Compensation rings should be fitted to the shell and vent holes should be provided in them. The thickness of the compensation ring should preferably not exceed the thickness of the shell.</p>				
<p><b>3.1 Set-on branches</b></p>				
3.1.1		<p>5 mm ≤ a = 0,5 t<sub>3</sub>                      b ≥ 7 mm                      α ≥ 15°                      1 for shell to branch                      joints, see Table 2</p>		1.9.1 or 1.11 and 1.10

Table 3 (continued)

no.	Figure	Application/ condition	Note	Reference to EN ISO 9692-1:2003 and EN ISO 9692- 2:1998
<b>3.2 Set-in branches</b>				
<p><b>Gap between branch and shell.</b> It is recommended that the gap between the branch and the shell, also the compensation ring, should not exceed 3 mm. Wider gaps increase the tendency to spontaneous cracking during welding, particularly as the thickness of the parts joined increases.</p>				
<p><b>Internal compensation ring.</b> Set-in branches with a single compensation ring has been shown with the ring on the outside of the shell, which is the normal case. Similar connections may be used for the attachment of internal compensation ring in the formed end of pressure vessel and in spherical vessel.</p>				
3.2.1		$5 \text{ mm} \leq a = 0,5 t_3$ $b \geq 7 \text{ mm}$ $30^\circ \leq \alpha \leq 45^\circ$ $\beta \geq 20^\circ$	Compensation of the branches with big wall thickness is preferred to compensation rings. For shell to branch joints, see Table 2 in Figure 2.2.7	2.9.1, 2.11 and 1.10 The reinforcements shall be checked by calculation. Reinforcements by nozzles with higher wall thickness shall be preferred to discoidal reinforcements. $\alpha = 60^\circ$ $a = 0,5 t_3$ $h > 0,7 t_3$ $t_3 < t_2$ $a = 0,7 t_3$ $2 \text{ mm} \leq b_1 \leq 4 \text{ mm}$ $b_2 \geq 7 \text{ mm}$ $\beta \geq 20^\circ$ $z \approx 0,3 t_3$

Table 4 — Sockets and couplings

no.	Figure	Application/ condition	Note	Reference to EN ISO 9692-1:2003 and EN ISO 9692- 2:1998
<b>4.1 Sockets and couplings</b>				
4.1.1		$m = 1,5 \text{ mm}$	Small couplings in 4.1.1 to 4.1.3 inclusive may be attached to shells by the connections and (with the exception of 4.1.3) by any other appropriate joint shown in Figures 2.3.1 to 2.5.1. Applications especially for attachments, e.g. temperature and pressure sensors.	3.1.1 and 4.1.3
4.1.2			see 4.1.1	4.1.3
4.1.3		$m = 1,5 \text{ mm}$	see 4.1.1 Not suitable when crevice corrosion is expected.	3.1.2 and 1.9.1

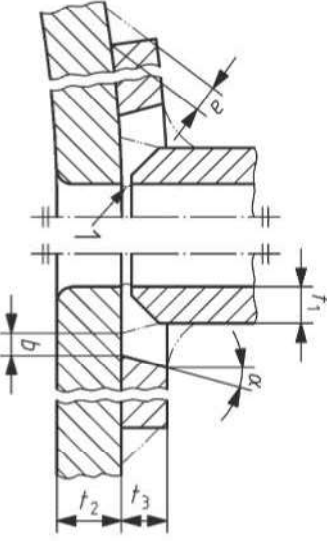
Table 4 (continued)

no.	Figure	Application/ condition	Note	Reference to EN ISO 9692-1:2003 and EN ISO 9692- 2:1998
4.1.4		$m = 1,5 \text{ mm}$	Applications especially for attachments, e.g. temperature and pressure sensors. Not suitable when crevice corrosion is expected.	

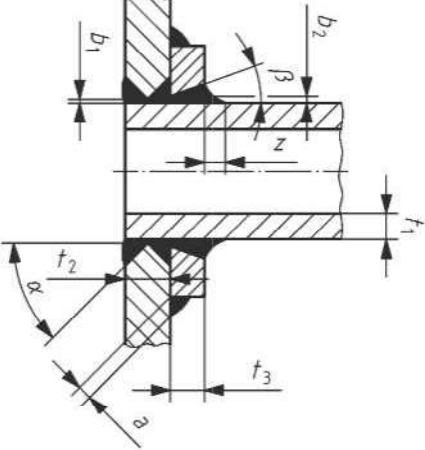
Table 5 — Flanges

no.	Figure	Application/ condition	Note	Reference to EN ISO 9692-1:2003 and EN ISO 9692- 2:1998
<p>Due to distortion it may be necessary to machine the flange-face after welding. The clearance between the bore of the flange and the inner diameter of the branch shall not exceed 2 mm. In the case of thick set-on flanges a radial vent hole through the flange may be useful.</p>				
<b>5.1 Flanges (<math>t</math> is the tube thickness)</b>				
5.1.1		<p>After machining flange to final thickness. <math>h_1 \geq 0,7 t</math> <math>h_2 \geq 0,7 t</math></p>	<p>Face and back welded flange. For partial penetration welded connection.</p>	1.11 and 2.11
5.1.2		1 conventional butt weld	<p>Welding neck flange. Refer to Table 1 from 1.1.1 to 1.1.3</p>	1.5 or 1.3

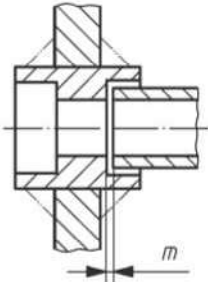
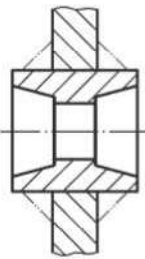
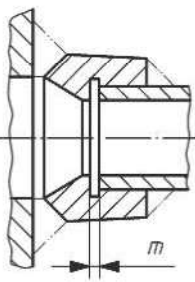

Table 5 (continued)

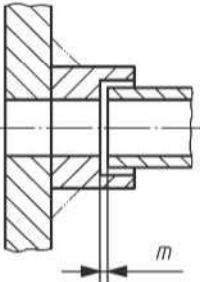
no.	Figure	Application/ condition	Note	Reference to EN ISO 9692-1:2003 and EN ISO 9692- 2:1998
5.1.3			Loose flange.	2.11 and 1.9.1
5.1.4		$a_1 = 0,7 t$ $a_2 = 0,7 t$ $b \leq 2 \text{ mm}$ $m \geq 3 \text{ mm}$ $4 \text{ mm} \leq t \leq 10 \text{ mm}$	Fillet welded flange.	3.1.2 and 3.1.1
5.1.5		$h_1 \geq 0,7 t$ $h_2 \geq 0,7 t$ $45^\circ \leq \alpha_1 \leq 60^\circ$ $\alpha_2 = 30^\circ$		

Table 5 (continued)

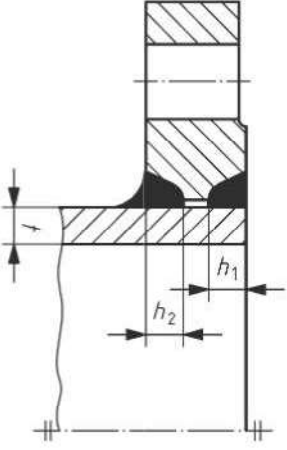
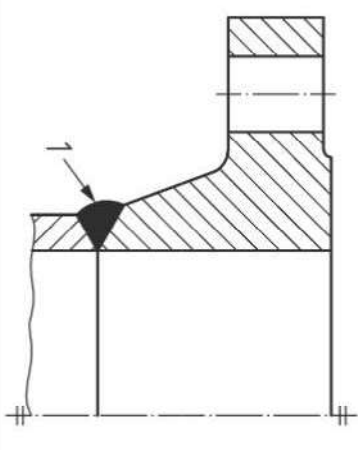
no.	Figure	Application/ condition	Note	Reference to EN ISO 9692-1:2003 and EN ISO 9692- 2:1998
5.1.6		<p> <math>r = 7 \text{ mm}</math>  <math>h_1 \geq 0,7 t</math>  <math>h_2 \geq 0,7 t</math>  <math>45^\circ \leq \alpha_1 \leq 60^\circ</math>  <math>10^\circ \leq \alpha_2 \leq 20^\circ</math> </p>		
5.1.7		<p> <math>r = 7 \text{ mm}</math>  <math>10^\circ \leq \alpha \leq 20^\circ</math>  <math>a \geq 0,7 t</math>  <math>h \geq 0,7 t</math> </p>		

Table 5 (continued)

no.	Figure	Application/ condition	Note	Reference to EN ISO 9692-1:2003 and EN ISO 9692- 2:1998
5.1.8		$a \geq 0,7 t$ $5 \text{ mm} \geq m = 0,5 t$ $b \geq 5 \text{ mm}$ $n \geq 5 \text{ mm}$ $\alpha = 15^\circ$		1.4
5.1.9		1 conventional butt weld	For lower pressures and smaller pipe diameters or pipes in stainless steel with flange made of carbon steel.	1.3

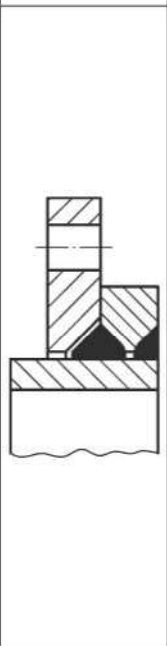
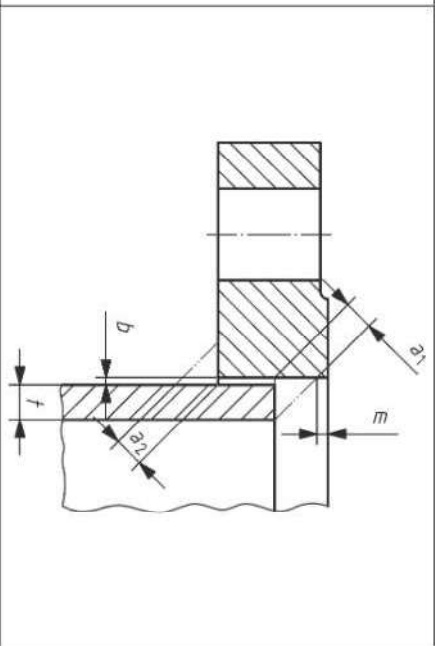
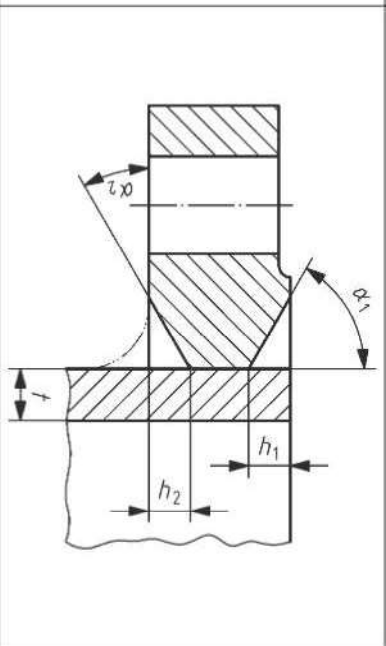
Table 6 — Jacketed vessels

no.	Figure	Application/ condition	Note	Reference to EN ISO 9692-1:2003 and EN ISO 9692- 2:1998
<p>It is recommended that the gap between the shell of the vessel and the jacket or blocking ring should not exceed 3 mm. A blocking ring should be machined to a circumferential length not more than 5 mm greater than that of the vessel. Wider gaps increase the tendency to spontaneous cracking during welding, particularly as the thickness of the parts increase.</p>				
<b>6.1 Attachment of jackets</b>				
6.1.1		<p>1 jacket 2 shell <math>2 \text{ mm} \leq b \leq 4 \text{ mm}</math> <math>45^\circ \leq \alpha_1 \leq 60^\circ</math> <math>35^\circ \leq \alpha_2 \leq 60^\circ</math></p>	<p>— As service conditions become more severe, change to full penetration weld; — in difficult situations, chamfering the blocking ring will help to avoid cracking; — if the shell plate is stressed in direction of its thickness, it shall be examined for laminations before welding the jacket.</p>	

Table 6 (continued)

no.	Figure	Application/ condition	Note	Reference to EN ISO 9692-1:2003 and EN ISO 9692- 2:1998
6.1.2		$a \geq 0,7 t$ $b \leq 2 \text{ mm}$	see 6.1.1	4.1.3 and 1.5
6.1.3		$t_2 \leq 15 \text{ mm}$ $45^\circ \leq \alpha \leq 60^\circ$ or as calculated 1 sealing run		

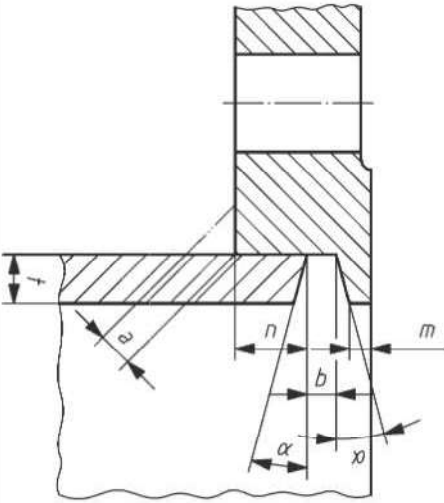
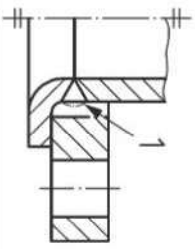
Table 6 (continued)

no.	Figure	Application/ condition	Note	Reference to EN ISO 9692-1:2003 and EN ISO 9692- 2:1998
6.1.4		<p>2 mm ≤ b ≤ 4 mm 45° ≤ α ≤ 60°</p>	<p>see 6.1.1</p>	<p>2.9.1</p>
6.1.5		<p>3 mm ≥ a ≥ 0,7 t α = 45°</p>		<p>1.9.1</p>
6.1.6		<p>α = 45°</p>		<p>2.9.1 and 1.9.1</p>

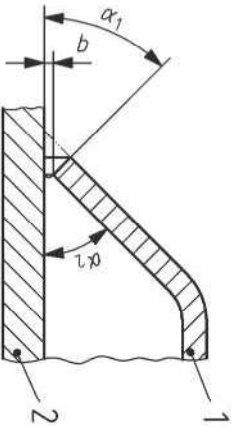
Table 6 (continued)

no.	Figure	Application/ condition	Note	Reference to EN ISO 9692-1:2003 and EN ISO 9692- 2:1998
<b>6.2 Blocking rings</b>				
6.2.1		$a = 0,5 t$ $b \leq 2 \text{ mm}$	Alternative ring to shell weld detail permissible when $t$ does not exceed 15 mm	4.1.3
6.2.2		1 see Figure 5.1.1 for weld size and profile		2.11

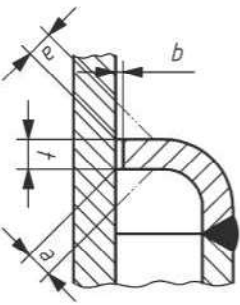
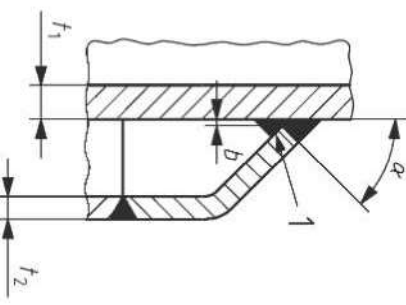
Table 6 (continued)

no.	Figure	Application/ condition	Note	Reference to EN ISO 9692-1:2003 and EN ISO 9692- 2:1998
<b>6.3 Intermediate connections between shell and jacket</b>				
6.3.1		$d \geq 2 m$		2.8 and 1.9.1
6.3.2		$3 \text{ mm} \geq a \geq 0,7 t$ $45^\circ \leq \alpha \leq 60^\circ$ $b = 2 \text{ mm}$		4.1.3 and 1.9.1
6.3.3		1 circular ring with vent holes	For use on pressure vessels, when there is no risk of corrosion.	3.1.2 and 3.1.1

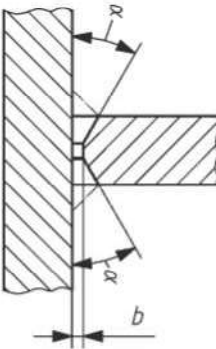
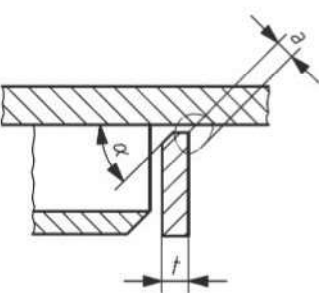
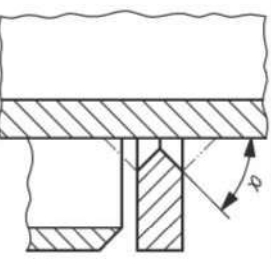

Table 6 (continued)

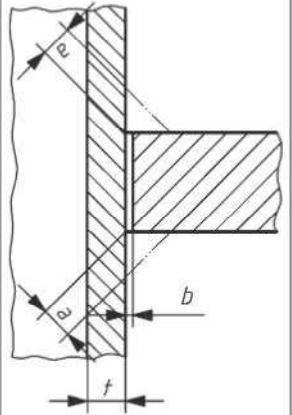
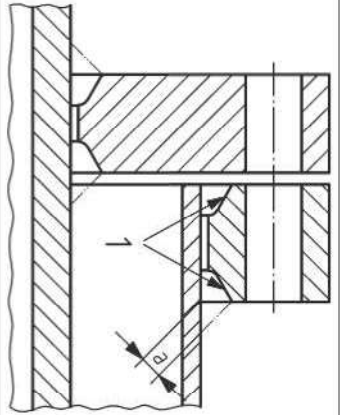
no.	Figure	Application/ condition	Note	Reference to EN ISO 9692-1:2003 and EN ISO 9692- 2:1998
6.3.4		<p><math>45^\circ \leq \alpha \leq 60^\circ</math> Dimensions defined by construction.</p>	<p>for b) and c) = For use on pressure vessels, when there is no risk of corrosion.</p>	<p>3.1.2 and 3.1.1</p>

Table 6 (continued)

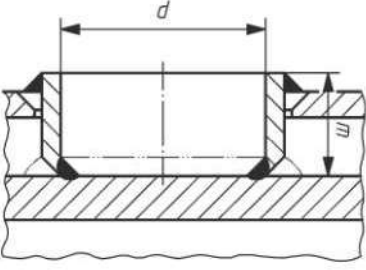
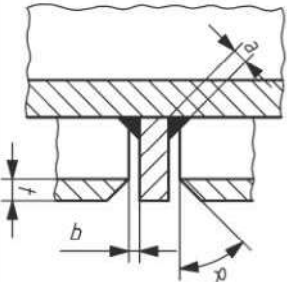
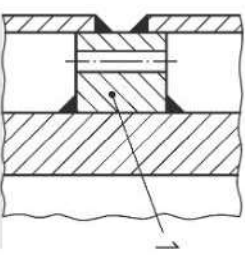
no.	Figure	Application/ condition	Note	Reference to EN ISO 9692-1:2003 and EN ISO 9692- 2:1998
<b>6.4 Branch connections</b>				
6.4.1		Inside shell accessible for welding. $\alpha = 45^\circ$	Not applicable for alternating bend stress, e.g. effected by temperature difference between inner vessel and outer shell of the vessel.	1.9.1
6.4.2		May be welded from the outside only. $\alpha_1 = 60^\circ$ $\alpha_2 = 45^\circ$	It is necessary to ensure good access to the weld between inner shell and branch.  Not applicable for alternating bend stress, e.g. effected by temperature difference between inner vessel and outer shell of the vessel.	1.9.1 and 1.3
6.4.3		1 gap 2 mm to 3 mm 2 good access to the weld between the inner shell and branch is required. $h \geq m$ $\alpha = 45^\circ$	These details are for use only when it is necessary for the jacket to extend up the branch.	1.9.1

Table 6 (continued)

no.	Figure	Application/ condition	Note	Reference to EN ISO 9692-1:2003 and EN ISO 9692- 2:1998
6.4.4		<p>If the branch to shell weld has to be welded on both sides, the branch jacket shall be made of two halves. Note welding sequence: I - II - III - IV. <math>\alpha = 45^\circ</math></p>	<p>see 6.4.3</p>	<p>1.3 and 1.9.1</p>
6.4.5		<p><math>f \geq 20 \text{ mm}</math></p>		<p>4.1.3</p>
6.4.6		<p><math>f \geq r</math></p>		<p>1.9.1</p>

Table 6 (continued)

no.	Figure	Application/ condition	Note	Reference to EN ISO 9692-1:2003 and EN ISO 9692- 2:1998
6.4.7			<p>These branch connections are preferably used in the heads of jacketed vessels. Some of the details may also be applied in other region of the jacketed vessels.</p> <p>Not applicable for alternating bend stress, e.g. effected by temperature difference between inner vessel and outer shell of the vessel.</p>	4.1.3 and 1.9.1
6.4.8		$10^\circ \leq \alpha \leq 20^\circ$ $b = 5 \text{ mm}$ $n > 2 \text{ mm}$	<p>For use on pressure vessels, when there is no risk of corrosion.</p>	
6.4.9		1 conventional butt weld		2.5.2 or 2.6 and 1.5

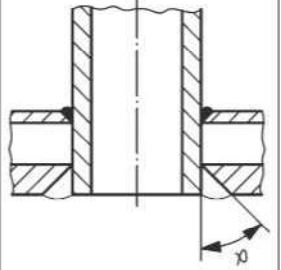
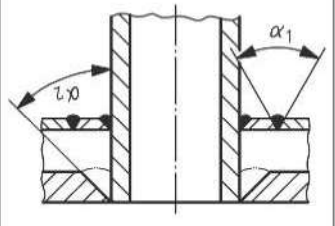
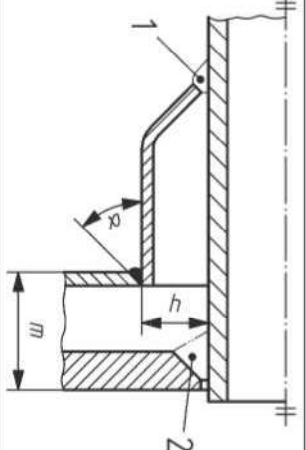
Table 6 (continued)

no.	Figure	Application/ condition	Note	Reference to EN ISO 9692-1:2003 and EN ISO 9692- 2:1998
<b>6.5 Alternatives to full jackets</b>				
Preformed elements welded to shell. Good accessibility is required for welding.				
6.5.1		<p>1 shell <math>\alpha = 45^\circ</math></p>		1.9.1
6.5.2		<p><math>\alpha_1 = 45^\circ</math> <math>\alpha_2 = 60^\circ</math> <math>2 \text{ mm} \leq b \leq 3 \text{ mm}</math></p>		1.9.1
6.5.3		<p><math>t \leq 2,6 \text{ mm}</math> <math>a \geq t</math></p>		
6.5.4		<p><math>3 \text{ mm} \geq a \geq t</math> <math>\alpha = 45^\circ</math> <math>c \leq 1 \text{ mm}</math> <math>t \geq 2,6 \text{ mm}</math></p>	Full penetration.	

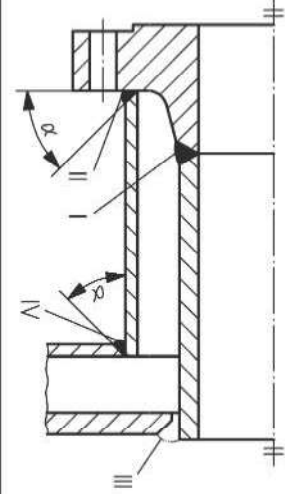
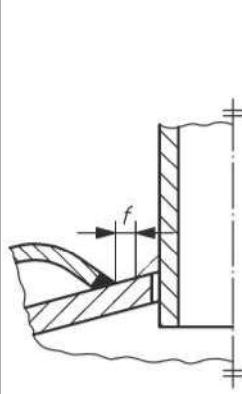
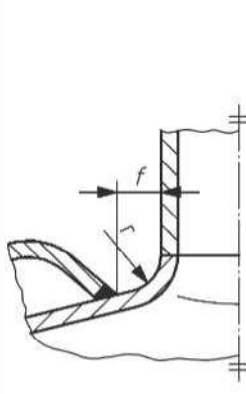
Table 6 (continued)

no.	Figure	Application/ condition	Note	Reference to EN ISO 9692-1:2003 and EN ISO 9692- 2:1998
6.5.5		$t > 2,6 \text{ mm}$ $2 \text{ mm} \leq b \leq 4 \text{ mm}$ $\alpha = 45^\circ$ $a \geq t$	Full penetration.	1.9.1
<b>6.6 Staybolt connections</b>				
To have the possibility of detecting cracks in the bolt.				
6.6.1		1 alternative weld preparation to 2	Staybolt normal arrangement.	1.9.1 and 1.9

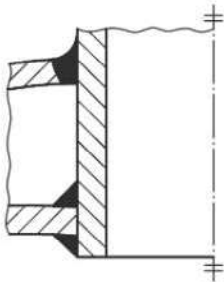
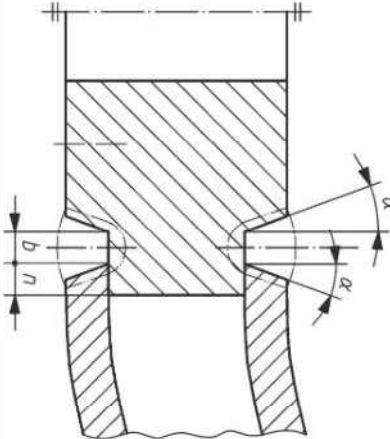
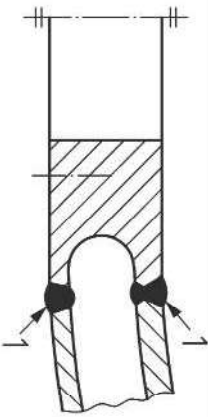
Table 7 — Tube to tube plate connection

no.	Figure	Application/ condition	Note	Reference to EN ISO 9692-1:2003 and EN ISO 9692- 2:1998
<p>Tubes are welded to tube plates by several processes like manual metal-arc welding and mainly by partly and fully mechanized TIG-welding. It is advisable to examine the tube plate for laminations before machining.</p> <p>Tubes shall closely fit their holes.</p> <p>Care should be taken to ensure that the tube ends and tube plate holes are clean before welding.</p> <p>The holes in the tube plates shall be deburred.</p> <p>If two runs are welded, the second run shall fully overlap the first one.</p>				
7.1.1		$t \leq 2,6 \text{ mm}$ $0 \text{ mm} \leq x \leq 2 \text{ mm}$		
7.1.2		$t > 2,6 \text{ mm}$ $x \geq 6 \text{ mm}$		3.1.1

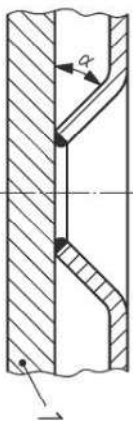
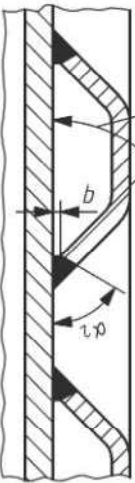
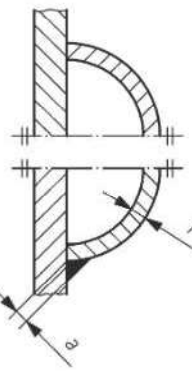
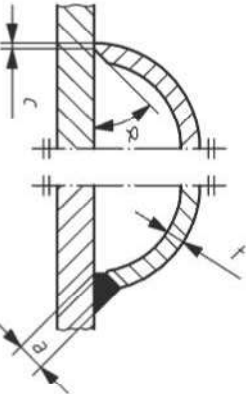
Table 7 (continued)

no.	Figure	Application/ condition	Note	Reference to EN ISO 9692-1:2003 and EN ISO 9692- 2:1998
7.1.3		$t > 2,6 \text{ mm}$ $t \leq h \leq 1,5 t$ $x = h - 1 \text{ mm}$ $r = t$		
7.1.4		$h \approx t$ $x = h - 1 \text{ mm}$ $t \geq 5 \text{ mm}$ $45^\circ \leq \alpha \leq 60^\circ$		
7.1.5		$w = t$ $h \approx t$ $1,5 \text{ mm} \leq m \leq 2 t$ $t \geq 5 \text{ mm}$ $\alpha = 30^\circ$		

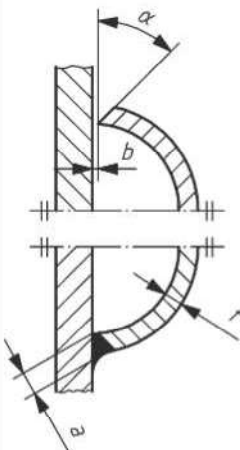
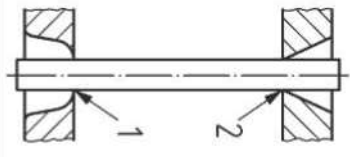

Table 7 (continued)

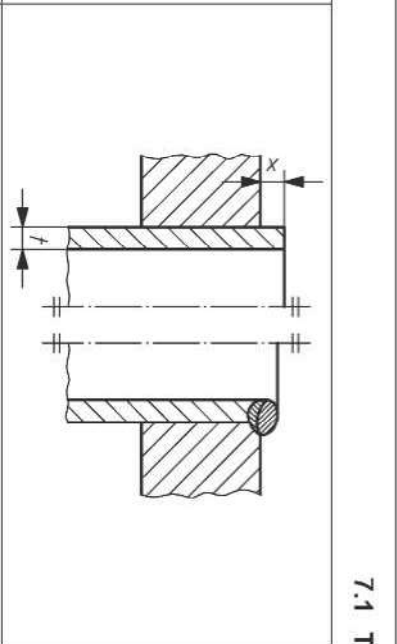
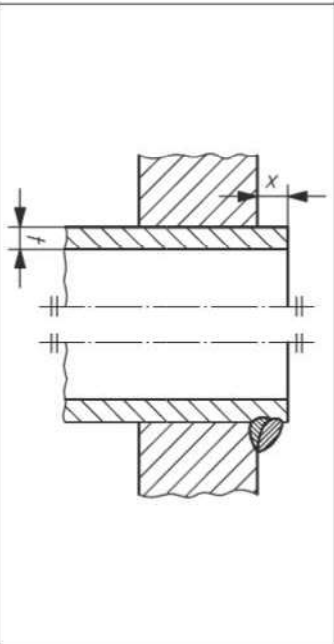
no.	Figure	Application/ condition	Note	Reference to EN ISO 9692-1:2003 and EN ISO 9692- 2:1998
7.1.6		$w = t$ $1,5 \text{ mm} \leq m \leq 2 t$ for $t < 5 \text{ mm}$		1.1
7.1.7		$w = t$ $x = 0,5 w$ $0,5 \text{ mm} \leq m \leq 2 t$ $h = 0,5 t$	Internal bore welding. Only for fully mechanized TIG- welding.	

Table 7 (continued)

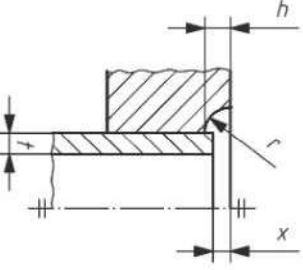
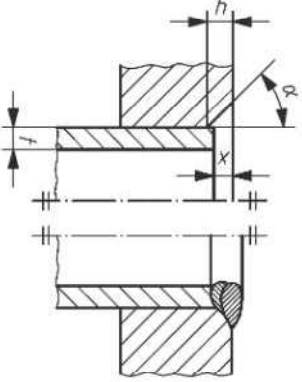
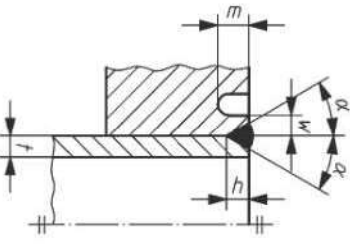
no.	Figure	Application/ condition	Note	Reference to EN ISO 9692-1:2003 and EN ISO 9692- 2:1998
7.1.8		$x = 0,5 w$ $h = 0,5 t$ $1,5 \text{ mm} \leq m \leq 2 t$ $w = t$	see 7.1.7	
7.1.9		$l \geq 1,5 t$		

Table 8 — Flat end or tube plate to shell connections

no.	Figure	Application/ condition	Note	Reference to EN ISO 9692-1:2003 and EN ISO 9692- 2:1998
<b>8.1 Flat end or tube plate to shell connections</b>				
When using details like 8.1.1, 8.1.2, 8.1.3, 8.1.7, 8.1.8, 8.1.9 special care shall be taken to ensure that the end plate is not laminated.				
8.1.1		$a \geq 0,7 t$	Accessible for welding on both sides of the shell.	4.1.3
8.1.2				2.9.1 or 2.11
8.1.3		$a \geq 5 \text{ mm}$ $\alpha = 45^\circ$	Typical connections used in the construction of waste heat boilers, economizers and fireboxes.	1.9.1

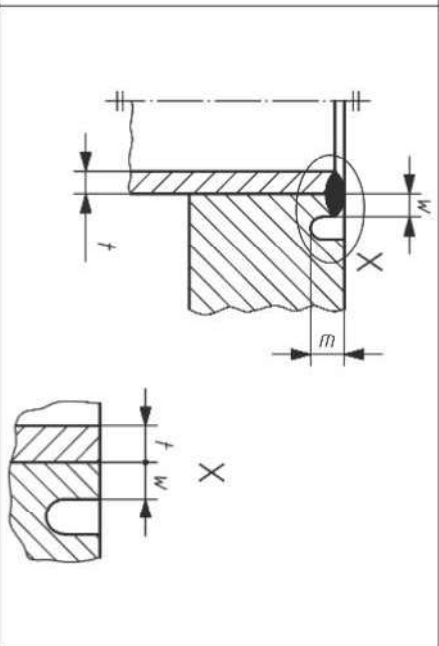
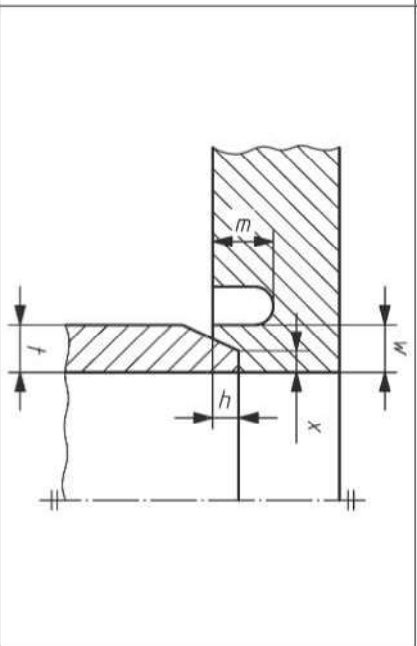
Table 8 (continued)

no.	Figure	Application/ condition	Note	Reference to EN ISO 9692-1:2003 and EN ISO 9692- 2:1998
8.1.4	 <p>The diagram shows a cross-section of a flange with a chamfered edge. Dimension <math>t_1</math> is the chamfer width, <math>t_2</math> is the flange thickness, <math>t</math> is the main plate thickness, and <math>\alpha</math> is the chamfer angle.</p>	$t_2 \leq 15 \text{ mm}$ $t = t_1$ $45^\circ \leq \alpha \leq 60^\circ$	<p>For thin tube plates and for thick flanges.</p>	3.1.1

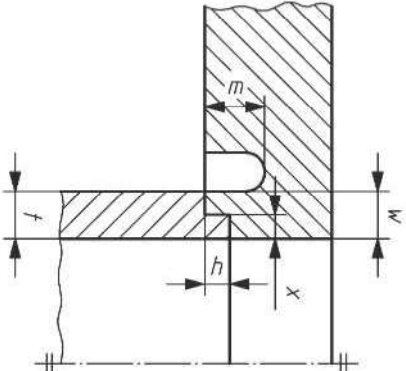
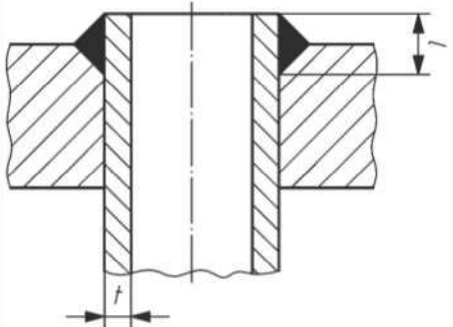
Table 8 (continued)

no.	Figure	Application/ condition	Note	Reference to EN ISO 9692-1:2003 and EN ISO 9692- 2:1998
8.1.5	 <p style="text-align: center;">Alternative joints details</p>	$a \geq 0,7 t$		<p>4.1.3</p> <p>1.9.1 and 2.10</p> <p>2.9.1</p> <p>2.11</p>

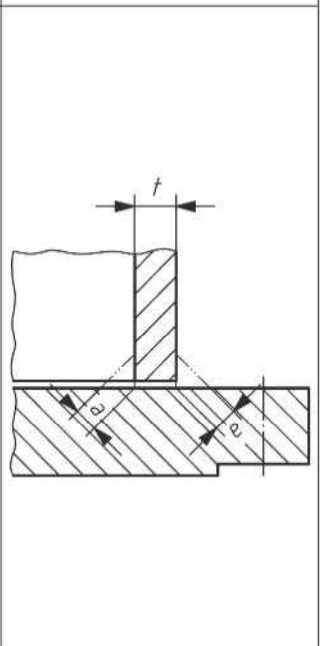
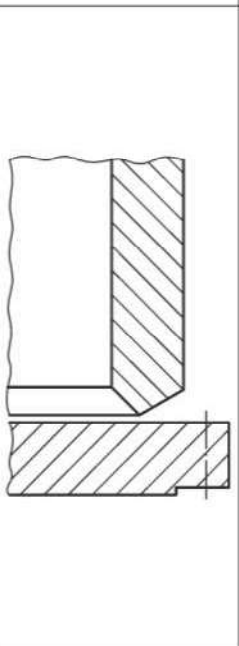
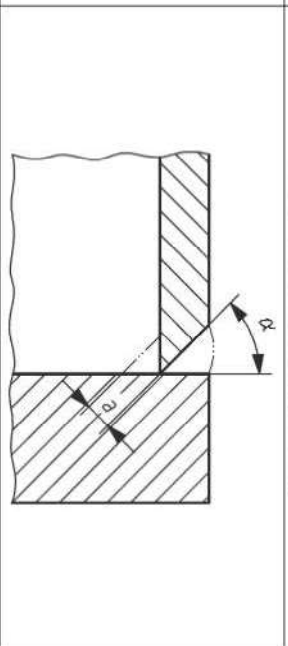
Table 8 (continued)

no.	Figure	Application/ condition	Note	Reference to EN ISO 9692-1:2003 and EN ISO 9692- 2:1998
8.1.6		<p><math>a \geq 0,7 t</math></p> <p>1 Instead of a cylindrical extension and a transition weld, the protruding part may be machined off.</p>		2.10
8.1.7		<p><math>n \geq 2 \text{ mm}</math></p> <p>Greater values of <math>\alpha</math> are to be related to lower values of <math>b</math> and vice versa, e.g.:</p> <p><math>\alpha = 10^\circ</math> and <math>b = 15 \text{ mm}</math> or <math>\alpha = 40^\circ</math> and <math>b = 5 \text{ mm}</math></p>	<p>Permissible only for low static loading and when there is no risk of corrosion.</p>	1.4

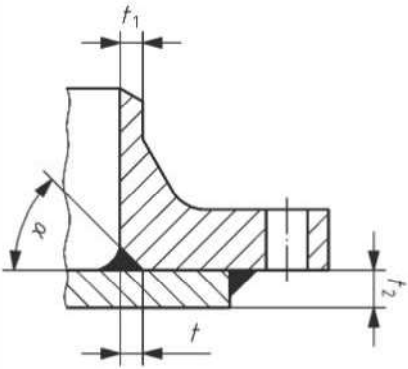
Table 8 (continued)

no.	Figure	Application/ condition	Note	Reference to EN ISO 9692-1:2003 and EN ISO 9692- 2:1998
8.1.8		<p><math>a \approx 3 \text{ mm}</math></p> <p>Greater values of <math>\alpha</math> are to be related to lower values of <math>b</math> and vice versa, e.g.:</p> <p><math>\alpha = 10^\circ</math> and <math>b = 15 \text{ mm}</math> or <math>\alpha = 40^\circ</math> and <math>b = 5 \text{ mm}</math></p> <p><math>n \geq 2 \text{ mm}</math></p>	<p>See 8.1.7</p>	<p>3.1.1</p>
8.1.9		<p><math>n \geq 3 \text{ mm}</math></p>	<p>The shape of the groove in the flate end shall be designed depending on the service conditions. Not accepted for collectors in power plants.</p>	<p>1.5</p>

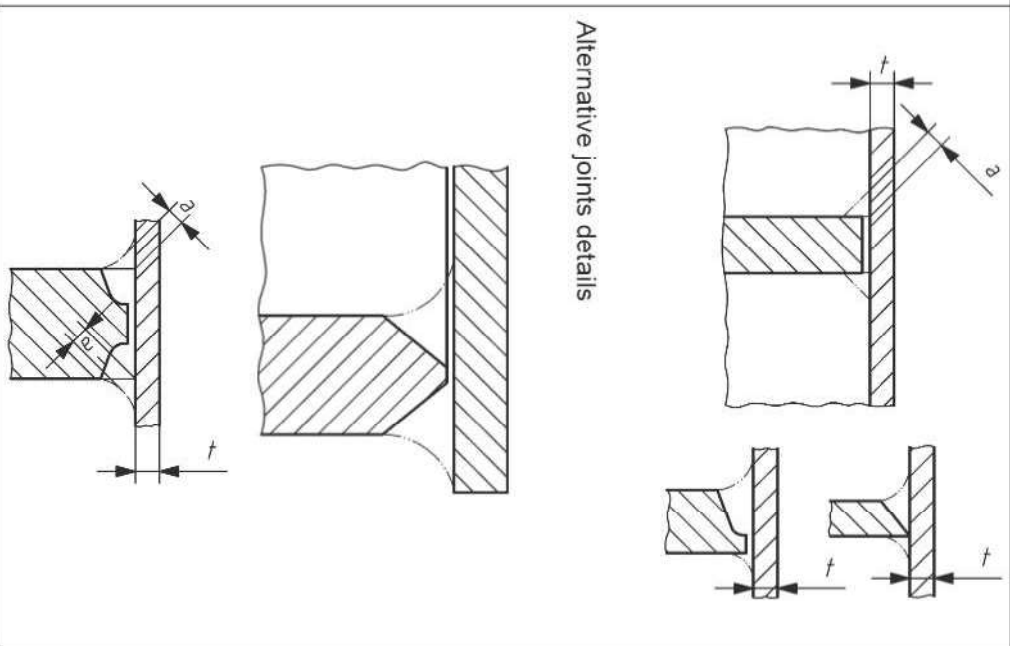
Table 8 (continued)

no.	Figure	Application/ condition	Note	Reference to EN ISO 9692-1:2003 and EN ISO 9692- 2:1998
8.1.10		<p><math>d_1 \leq 600</math> mm  <math>r_{fk} \geq 0,3 e_h</math>,  but also <math>r_{fk} \geq 5</math> mm</p>		
8.1.11		<p><math>r_{fk} \geq 0,3 e_s</math>,  but also <math>r_{fk} \geq 5</math> mm</p>		

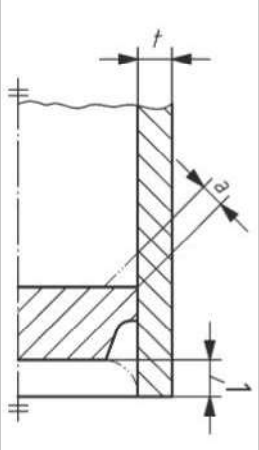
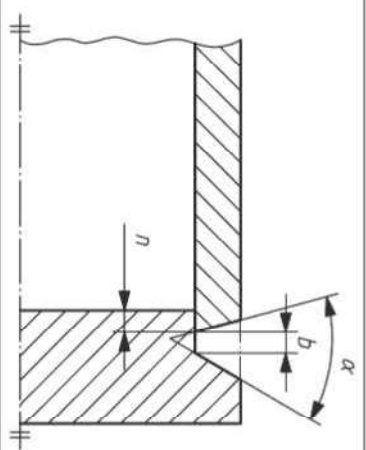

Table 8 (continued)

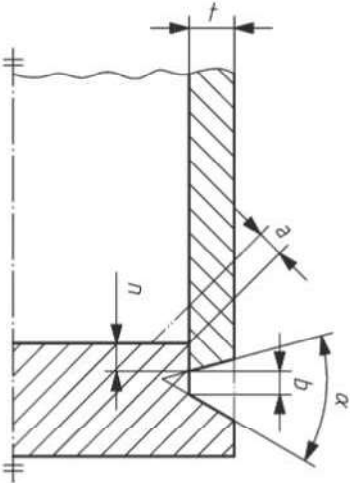
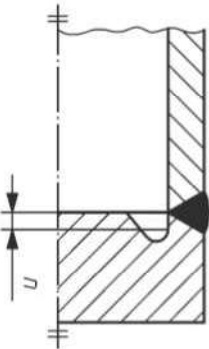
no.	Figure	Application/ condition	Note	Reference to EN ISO 9692-1:2003 and EN ISO 9692- 2:1998
8.1.12		$d_1 \leq 600$ mm	Not recommended for use if cyclic loading is expected to occur.	
8.1.13		$d_1 \leq 600$ mm	Not recommended for use if cyclic loading is expected to occur.	

Table 9 — Internal diaphragms and separators

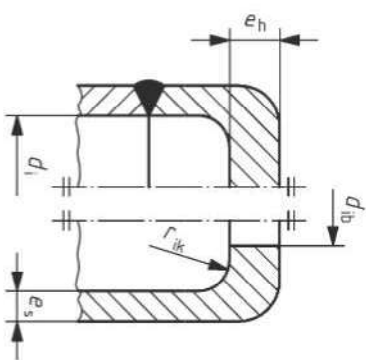
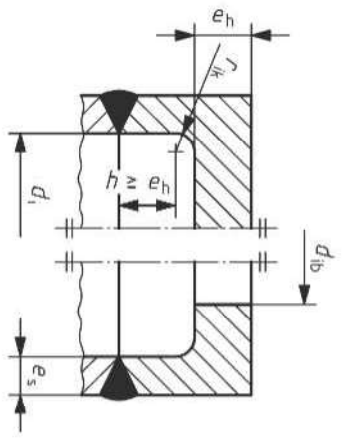
no.	Figure	Application/ condition	Note	Reference to EN ISO 9692-1:2003 and EN ISO 9692- 2:1998
<b>9.1 Internal diaphragms and separators</b>				
Stationary vessels only, suitable for differential pressure.				
9.1.1			Only for use when there is no risk of corrosion.	3.1.2
9.1.2		$a \geq 0,7 t_3$ $25 \text{ mm} \geq n \geq 2 t_3$ $10 \text{ mm} \geq b \leq 0,5 t_1$ $m \geq t_3 + 5 \text{ mm}$ $\alpha = 30^\circ$	Only for use when there is no risk of corrosion.	1.5 and 3.1.2
9.1.3			Conventional butt welds.	2.5.1 and 2.2

Table 10 — Supports and non-pressure parts

no.	Figure	Application/ condition	Note	Reference to EN ISO 9692-1:2003 and EN ISO 9692- 2:1998
<p><b>Influence of non-pressure parts.</b> The welding consumables, the material and design of the non-pressure parts shall be such as to avoid unfavourable influencing the quality of the pressure loaded parts. This applies in particular with respect to high yield-strengths materials.</p> <p><b>Doubling plates.</b> Doubling plates shall be used when attachment of non-pressure parts directly to the shell would cause unacceptable stress concentrations.</p> <p><b>Slots.</b> In the case of slots, it shall be wide enough to allow a continuous fillet weld.</p> <p><b>Welding after final post-weld heat treatment.</b> Welding of vessels, which have already been heat treated, is not permitted.</p> <p><b>Lifting facilities.</b> Lifting facilities shall be made of the material which will avoid brittle fracture in low ambient temperatures.</p> <p><b>Vent holes.</b> Where doubling plates are fitted before stress relief one or more vent holes shall be drilled in the plate.</p> <p><b>Corner radii.</b> Corners of doubling plate to be radiused to not less than three times thickness.</p>				
<p><b>10.1 Supports for vessels</b></p>				
10.1.1			<p>Vertical intermediate plate could be necessary.</p>	1.9.1

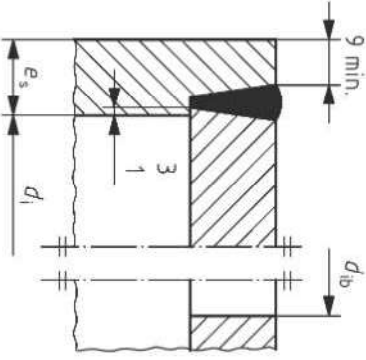
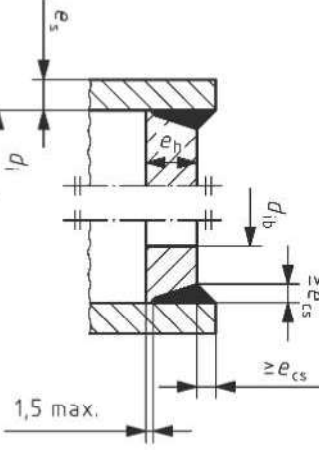
Table 10 (continued)

no.	Figure	Application/ condition	Note	Reference to EN ISO 9692-1:2003 and EN ISO 9692- 2:1998
10.1.3	 <p>Stiffener plates with or without mousehole</p>	$a_1 = 0,5 t_2$ $a_2 \geq 0,5 t_3$ for $t_1 \leq 15$ mm, $t_2 = t_1$ for $t_1 > 15$ mm, $t_2 < t_1$ $f \geq 10$ mm	If the saddle is to be welded on the shell the following conditions shall apply: for $t_1 \leq 15$ mm, $t_2 = t_1$ for $t_1 > 15$ mm, $t_2 < t_1$ $a \leq 0,7 t_1$ The weld shall be continued around the connecting part with $r \geq 30$ mm.	

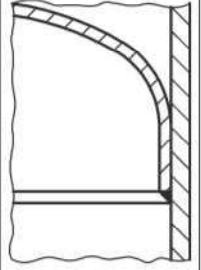
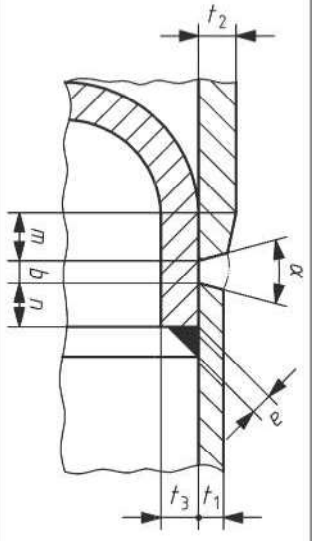
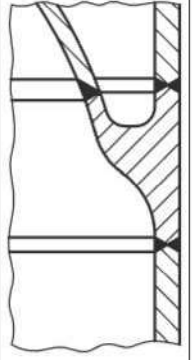
Table 10 (continued)

no.	Figure	Application/ condition	Note	Reference to EN ISO 9692-1:2003 and EN ISO 9692- 2:1998
10.1.4		$a \geq 4 \text{ mm}$	For small vertical vessels.	

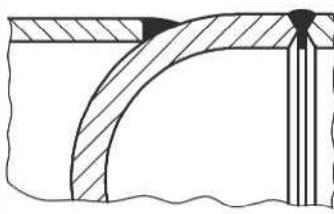
Table 10 (continued)

no.	Figure	Application/ condition	Note	Reference to EN ISO 9692-1:2003 and EN ISO 9692- 2:1998
<b>10.2 Supports for jacketed vertical vessels</b>				
10.2.1		$r \geq 10 \text{ mm}$ $m = 20 \text{ mm}$ $t_1 \leq t_2 \leq 1,5 t_1$ $a_1, a_2 = a$ $t_1, t_2 = t$ $a \leq 0,7 t_{min}$	All welds are circumferential. One vent hole required in the doubing plate.	

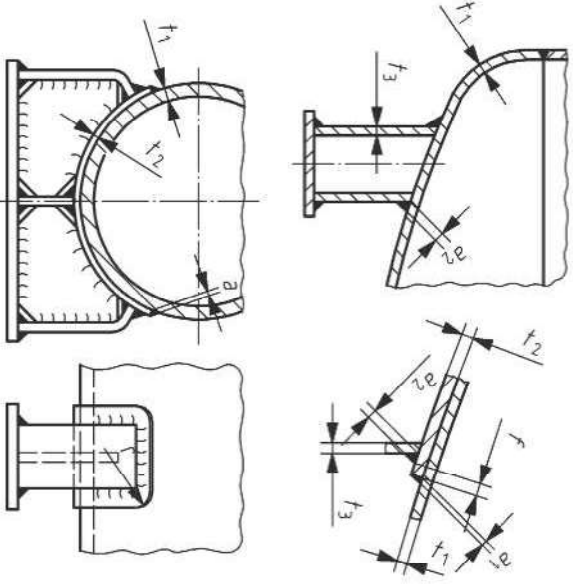
Table 10 (continued)

no.	Figure	Application/ condition	Note	Reference to EN ISO 9692-1:2003 and EN ISO 9692- 2:1998
<b>10.3 Non-pressure parts</b>				
10.3.1		$a_1, a_2 = a$ $t_1, t_2, t_3 = t$ $a \leq 0,7 t_{min}$ $t_1 \leq t_2 \leq 1,5 t_1$ 1 vent hole	Lifting lug for heavy loads.	

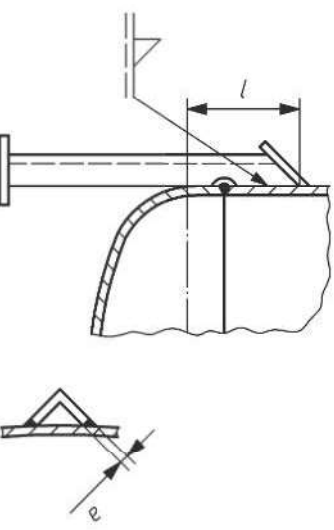
Table 10 (continued)

no.	Figure	Application/ condition	Note	Reference to EN ISO 9692-1:2003 and EN ISO 9692- 2:1998
10.3.2		$a_1, a_2 = a$ $t_1, t_2, t_3 = t$ $a \leq 0,7 t_{\min}$ $t_1 \leq t_2 \leq 1,5 t_1$ $r \geq 10 \text{ mm}$ 1 vent hole		

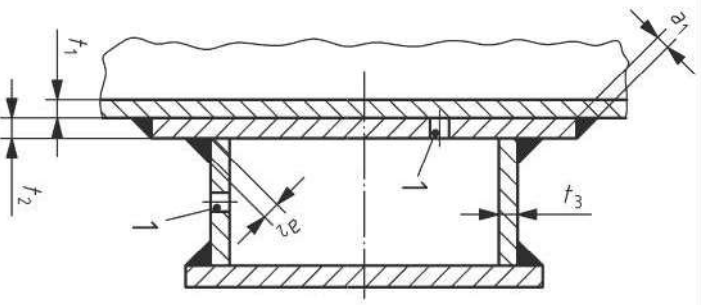

Table 10 (continued)

no.	Figure	Application/ condition	Note	Reference to EN ISO 9692-1:2003 and EN ISO 9692- 2:1998
10.3.3		$a_1, a_2 = a$ $t_1, t_2, t_3 = t$ $a \leq 0,7 t_{min}$ $a_3 = 0,5 t_1$ $t_3 \leq t_2 \leq 1,5 t_3$ 1 vent hole		
10.3.4		1 vent hole		

Table 11 — Special shell to head end connections

no.	Figure	Application/ condition	Note	Reference to EN ISO 9692-1:2003 and EN ISO 9692- 2:1998
<b>11.1 Joggle point</b>				
11.1.1		$t \leq 8 \text{ mm}$	Only for use when there is no risk of corrosion, fatigues, vibration and service conditions.	

Table 12 — Weld ring seal

no.	Figure	Application/ condition	Note	Reference to EN ISO 9692-1:2003 and EN ISO 9692- 2:1998
<b>12.1 Weld ring seal</b>				
12.1.1		$\alpha = 120^\circ$ $m = 5 \text{ mm}$ $n = 6,5 \text{ mm}$ $q = 15 \text{ mm}$ $t = 3,5 \text{ mm}$	<p>Buttering on the flange side may be necessary at the location where the fillet weld is to be made.</p>	
12.1.2		$\alpha = 120^\circ$ $\beta = 20^\circ$ $t = 4 \text{ mm}$	<p>Buttering on the flange side may be necessary at the location where the fillet weld is to be made.</p>	

Table 12 (continued)

no.	Figure	Application/ condition	Note	Reference to EN ISO 9692-1:2003 and EN ISO 9692- 2:1998
12.1.3		$\alpha = 120^\circ$ $m = 5 \text{ mm}$ $q = 15 \text{ mm}$	<p>Buttering on the flange side may be necessary at the location where the fillet weld is to be made.</p>	

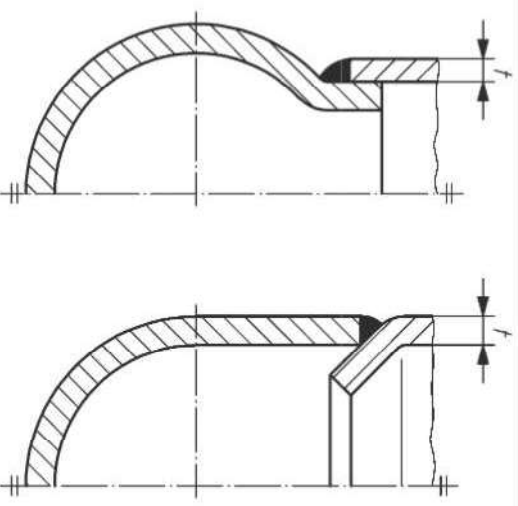
Table 13 — Pipe details

no.	Figure	Application/ condition	Note	Reference to EN ISO 9692-1:2003 and EN ISO 9692- 2:1998
Pipe butt joints.				
Butt joints incorporating backing rings.				
Permanent backing rings may be used for butt welding of pipes that do not carry corrosive fluids provided proper precautions are taken to ensure freedom from non-metallic inclusions and root cracks. They are not recommended in case of fatigue load.				
These precautions include the following:				
— The gap between the ring and the bores of both pipes shall be kept to a minimum and in no case should exceed 0,4 mm. This will require the pipe ends to be bore trimmed by machining for roundness, and fit.				
— Particular attention should be paid to such factors as the root gap, the root face, the thickness of the backing ring and the welding procedure.				
— The backing ring should not cause the joint to be restrained whilst contracting.				
— The misalignment is contained in EN ISO 5817.				
— In the case of corrosion, fatigue or creep the use of backing rings is generally not recommended.				

Table 13 (continued)

no.	Figure	Application/ condition	Note	Reference to EN ISO 9692-1:2003 and EN ISO 9692- 2:1998
<b>13.1 Socket joints</b>				
Socket joints are permitted on pipes with external diameter lower than 80 mm, with the dimensions indicated on 13.1.1.				
Socket joints are anyway excluded:				
— for steel pipes special applications;				
— in parts exposed to fumes or to flame radiation;				
— in those cases in which the service conditions, with particular regard to corrosion and fatigue stress, compromise the socket joint safety, in the opinion of the manufacturer.				
13.1.1		$d_3 \leq 80 \text{ mm}$ $c \geq 1,25 t$ $s \geq 1,5 t$ $m \geq 10 \text{ mm}$ $b_1 \geq 1,5 \text{ mm}$ $b_2 \geq 1 \text{ mm}$ $k \geq t$		3.1.2

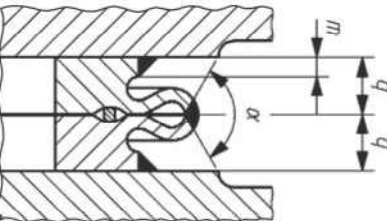
Table 13 (continued)

no.	Figure	Application/ condition	Note	Reference to EN ISO 9692-1:2003 and EN ISO 9692- 2:1998
<b>13.2 Special branch connections</b>				
In case of corrosion, fatigue, vibration service conditions the use of backing rings is generally not recommended. For normal cases see Table 2.				
13.2.1		<p>2 mm ≤ b ≤ 4 mm 1 mm ≤ c ≤ 3 mm 45° ≤ α ≤ 60°</p>	<p>Equal set-on branch with bevel (for unequal branch connections see Table 2).</p> <p>1 When the hole in the main pipe is thermal cut the ledge illustrated should be removed by grinding if required. Alternatively, if the hole in the main pipe is prepared by machining this ledge will not be obtained.</p>	
13.2.2		<p>The maximum angle β of slope should be 30° from the normal. Where the angle is greater than 30° special consideration shall be given to joint design and fabrication.</p> <p>α ≥ 45° 2 mm ≤ b ≤ 4 mm 1 mm ≤ c ≤ 3 mm</p>	<p>Set-on sloping unequal branch with bevel.</p>	

Table 13 (continued)

no.	Figure	Application/ condition	Note	Reference to EN ISO 9692-1:2003 and EN ISO 9692- 2:1998
13.2.3		<p>1 3 mm ledge obtained when thermal cutting hole in main pipe, see condition in 13.2.1.</p> <p>2 Alternative profile. Main pipe ground locally to improve access.</p> <p>2 mm ≤ b ≤ 4 mm</p> <p>1 mm ≤ c ≤ 3 mm</p> <p><math>\alpha_1 = 45^\circ</math></p> <p><math>\alpha_2 \geq 35^\circ</math></p> <p><math>\beta \leq 30^\circ</math></p>	<p>Set-on sloping equal branch with bevel.</p>	

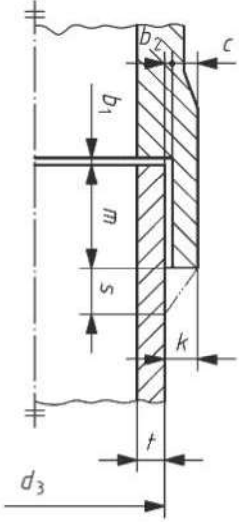

Table 13 (continued)

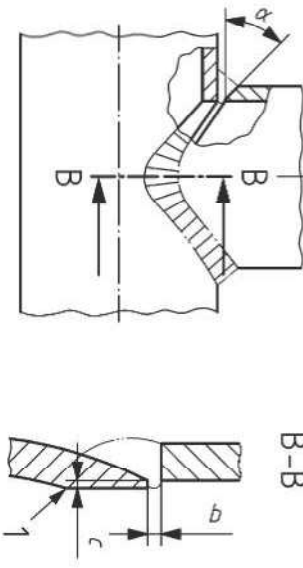
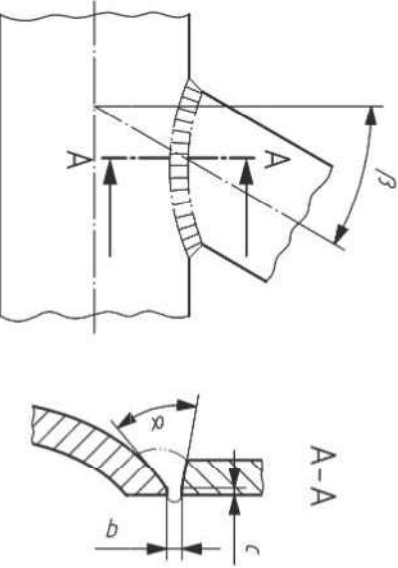
no.	Figure	Application/ condition	Note	Reference to EN ISO 9692-1:2003 and EN ISO 9692- 2:1998
13.2.4		$\alpha_1 \geq 60^\circ$ $\alpha_2 \geq 45^\circ$ $2 \text{ mm} \leq b \leq 4 \text{ mm}$ $1 \text{ mm} \leq c \leq 3 \text{ mm}$	Equal set-in branch.	
13.2.5		<p>The maximum angle <math>\beta</math> of slope shall be <math>30^\circ</math> from the normal. Where the angle is greater than <math>30^\circ</math> special consideration shall be given to joint design and fabrication.</p> $\alpha \geq 45^\circ$ $2 \text{ mm} \leq b \leq 4 \text{ mm}$ $1 \text{ mm} \leq c \leq 3 \text{ mm}$	Unequal set-in sloping branch.	

Table 13 (continued)

no.	Figure	Application/ condition	Note	Reference to EN ISO 9692-1:2003 and EN ISO 9692- 2:1998
13.2.6		<p>2 mm ≤ b ≤ 4 mm 1 mm ≤ c ≤ 3 mm</p> <p> <math>\alpha_1 \geq 45^\circ</math>  <math>\alpha_2 \geq 60^\circ</math>  <math>\alpha_3 \geq 45^\circ</math>  <math>\alpha_4 \geq 35^\circ</math>  <math>\beta \leq 30^\circ</math> </p>	see 13.2.5	

Table 14 — Block flanges

no.	Figure	Application/ condition	Note	Reference to EN ISO 9692-1:2003 and EN ISO 9692- 2:1998
<b>14.1 Inserted block flanges</b>				
14.1.1		<p>4 mm <math>\leq t_2 \leq 10</math> mm without additional stress <math>a = 0,7 t_2</math> <math>h \geq t_2</math></p>	<p>For spherical, shell and plane slab</p>	
14.1.2		<p>4 mm <math>\leq t_2 \leq 30</math> mm without additional stress <math>a = 0,7 t_2</math> <math>h \geq t_2</math> <math>45^\circ \leq \alpha \leq 60^\circ</math></p>		
14.1.3		<p>2 mm <math>\leq b \leq 4</math> mm <math>h = 0,5 t_2</math> <math>z \approx 0,3 t_2</math> <math>45^\circ \leq \alpha \leq 60^\circ</math></p>		

Table 14 (continued)

no.	Figure	Application/ condition	Note	Reference to EN ISO 9692-1:2003 and EN ISO 9692- 2:1998
14.1.4		<p>2 mm ≤ b ≤ 4 mm</p> <p><math>z \approx 0,3 t_2</math></p> <p>1 Flange shall be ground flush inside (e.g. discharging drain)</p> <p><math>45^\circ \leq \alpha \leq 60^\circ</math></p>	<p>Flange shall be flush inside (e.g. discharging spout)</p>	
14.1.5		<p><math>D_w = D + (1,5 \text{ to } 2) \times t_{2min}</math></p> <p>1 conventional butt weld</p>	<p>Universal for spherical and plane slab without limiting of wall thickness <math>t_2</math>, particularly for additional stress</p>	
14.1.6		<p>2 mm ≤ b ≤ 4 mm</p> <p><math>z \approx 0,3 t_2</math></p> <p><math>45^\circ \leq \alpha \leq 60^\circ</math></p>	<p>For spherical, shell and plane slab during one-sided load.</p>	

Table 14 (continued)

no.	Figure	Application/ condition	Note	Reference to EN ISO 9692-1:2003 and EN ISO 9692- 2:1998
<b>14.2 Added block flanges</b>				
14.2.1		<p><math>a = 0,5 t_2 \geq 5</math> mm  <math>z = 0,7 t_2</math>, whereas <math>t_2</math>  shall be measured  completely</p>	<p>For spherical, shell and plane  slab, if  <math>h \leq 3</math> mm  <math>t_2 \leq 30</math> mm  Tapped hole carry out as tapped  thorough hole or tapped blind  hole.  For <math>h \leq 1</math> mm (e.g. inspection  glasses) is  <math>a = 0,5 t_2 \geq 3</math> mm.</p>	
14.2.2		<p><math>h_2 \leq 3</math> mm, otherwise fit  <math>a = 0,5 t_2 \geq 5</math> mm  <math>z = 0,7 t_2</math>, whereas <math>t_2</math>  shall be measured  completely  <math>e = 0,5 t_2</math>, at least 10 mm</p>	<p>For spherical and shell, if  <math>h_1 \leq 15</math> mm  <math>t_2 \leq 30</math> mm  Tapped hole carry out as tapped  thorough hole or tapped blind  hole.</p>	

Table 14 (continued)

no.	Figure	Application/ condition	Note	Reference to EN ISO 9692-1:2003 and EN ISO 9692- 2:1998
14.2.3		<p><math>h_2 \leq 3</math> mm, otherwise fit  <math>t_1 \approx t_2</math>  <math>a = 0,5 t_2 \geq 5</math> mm  <math>a_1 = 0,5 t_2 \leq 6</math> mm  <math>z = 0,7 t_2</math>, whereas <math>t_2</math>  shall be measured  completely</p>	<p>For spherical and shell, if  <math>h_1 \geq 15</math> mm  <math>t_2 \leq 30</math> mm</p> <p>Tapped hole carry out as tapped  thorough hole or tapped blind  hole.</p>	

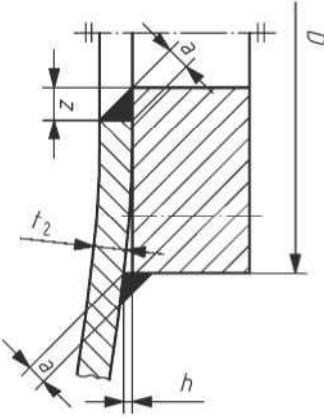
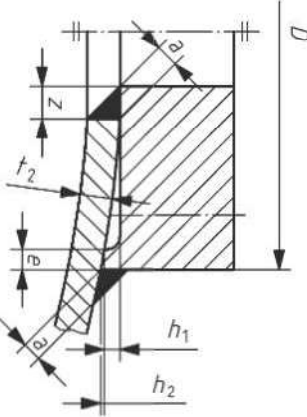
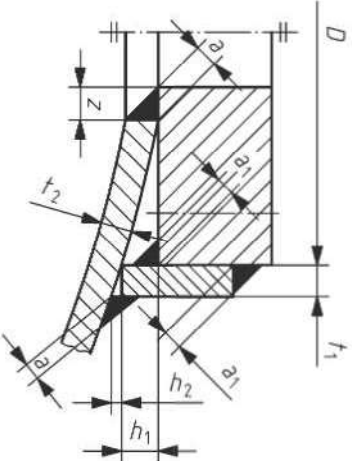